

CONSTRUCTION

- 100% hand-laid solid fiberglass hull lamination
- Vinylester resin in outer layers for superior blister resistance
- Bi-axial fiberglass cloth for added impact resistance
- Hydrex Max Guard brand ISO-NPG gelcoat
- Boot and Cove stripes painted with fade resistant LP paint
- Heavy duty longitudinal/floor/mast step/engine bed system
- All structure bonded securely to hull while in the mold
- No-liner interior construction provides direct access to entire hull
- Divinice cored deck lamination, contrasting color
- Deck through bolted and sealed with 3M 5200 polyurethane
- Bulkheads securely bonded on their entire perimeter, hull and deck
- Lead keel with bulb for maximum righting moment
- Balanced spade rudder with stainless steel rudder post
- Fresh water flush in main bilge

DECK FEATURES

- Lewmar MAMBA Direct Link Dual Steering
- Aquasignal LED Navigation lights
- All stanchions, pulpits, and handrails 316 stainless
- Lewmar deck hatches (Manship stainless option)
- Manship polished stainless steel opening ports
- Four stainless steel dorades with guards
- Hinged companionway doors/Lexan drop boards
- 30 inch high 1.25" diameter lifeline stanchions with 1x19 double lifelines
- 1.25" diameter stainless steel stern pulpit with aft gate
- Large bow sail/deck gear locker with watertight bulkhead
- 4 safety harness padeyes installed in cockpit
- USCG approved propane locker fits 2 20# tanks (1 provided)

PROPULSION

- Yanmar 110HP 4JH4-HTE KM4A w/ 2.45:1 gear fresh water cooled diesel
- Dual Racor fuel filter
- X-Chang-R oil change system
- Sounddown fireproof 2#/square foot engine compartment sound insulation
- 250 gallons(est) of fuel capacity in two tanks (additional capacity options)
- Fuel tanks vent to midship stanchions - well above waterline when heeled
- Hinged companionway steps and side panels for easy engine access

PLUMBING

- 225 gallon(est) fresh water capacity (additional capacity options)
- 16 gallon Isotherm stainless steel hot water heater
- Transom mounted hot and cold fresh water shower
- Fiberglass holding tanks with gravity feed overboard discharge
- Tank Watch holding tank indicators
- Sea Land Odor resistant hose used for all head plumbing
- Raritan PHII manual heads (electric option)
- Toilets plumbed for fresh and salt water

ELECTRICAL

- ABYC approved corrosion resistant tinned copper wire
- Victron Inverter/charger
- 110V Shore Power system with bow and stern connections
- House battery bank system includes four 8D deep cycle batteries
- Custom backlit electrical panels by Common Ground of Newport Beach
- Electrical panel hinged for easy access
- 12V utility plugs throughout vessel
- ABYC approved bonding system
- Copper SSB ground plane glassed to hull

INTERIOR FEATURES

- Cherry Interior
- Satin interior varnish
- Varnished Teak and Holly cabin sole
- Positive locking floorboards
- Hafele positive locking locker buttons
- Cedar Lined Hanging lockers
- Automatic hanging locker lights
- Louvered doors and cabinets for ventilation
- Mobella door handles
- Padded vinyl removable overhead panels
- Seamless Head compartments for easy cleaning
- Imtra Red/White LED interior lighting
- Courtesy/safety lighting throughout the cabin sole
- Individual reading lamps in each cabin
- Hella Fans throughout

GALLEY

- Corian counters with 2" cherry fiddles (Granite or Marble Options)
- Vitrifrigo Dual Refrigeration drawers
- Frigoboat Top Load Freezer System
- Force 10 three burner propane stove with oven
- Microwave locker
- Pull out trash bin under sink
- Oversized drawer under stove for pan stowage
- Jabsco salt water foot pump
- Jabsco fresh water foot pump
- Scandvik polished stainless double sink
- Scandvik faucet

GROUND TACKLE

- Divided self draining chain locker / forward stowage locker
- Custom stainless double anchor roller
- Molded scupper aft of bow roller
- Lewmar Windlass with capstan with handheld remote control
- Helm mounted windlass control and counter
- 250 feet Hi test anchor chain
- Delta anchor (or credit for buyers selection)
- Stern anchor and 200' 3-strand rode, 40 feet chain
- 6 12" stainless steel mooring cleats

SAILING HARDWARE

- Keel stepped Sparcraft rig with minimal spreader sweep
- 316 stainless steel 1X19 standing rigging
- T-900 Main, Genoa, Solant Low Stretch Halyards
- Sparcraft Rigid Boom Vang
- Harken Genoa Furler
- Harken Solant Furler
- 2 Lewmar 68CST Primaries (Electric Option)
- 1 Lewmar 48 ECST Electric main halyard winch
- 2 mast mounted Lewmar self tailing winches

SAILS:

- Hood Full batten Vectran main with Antal Low Friction Slides
- Hood Vectran Reacher/Genoa
- Hood Vectran Solant working jib
- Low stretch/low chafe Spectra Lazy Jacks

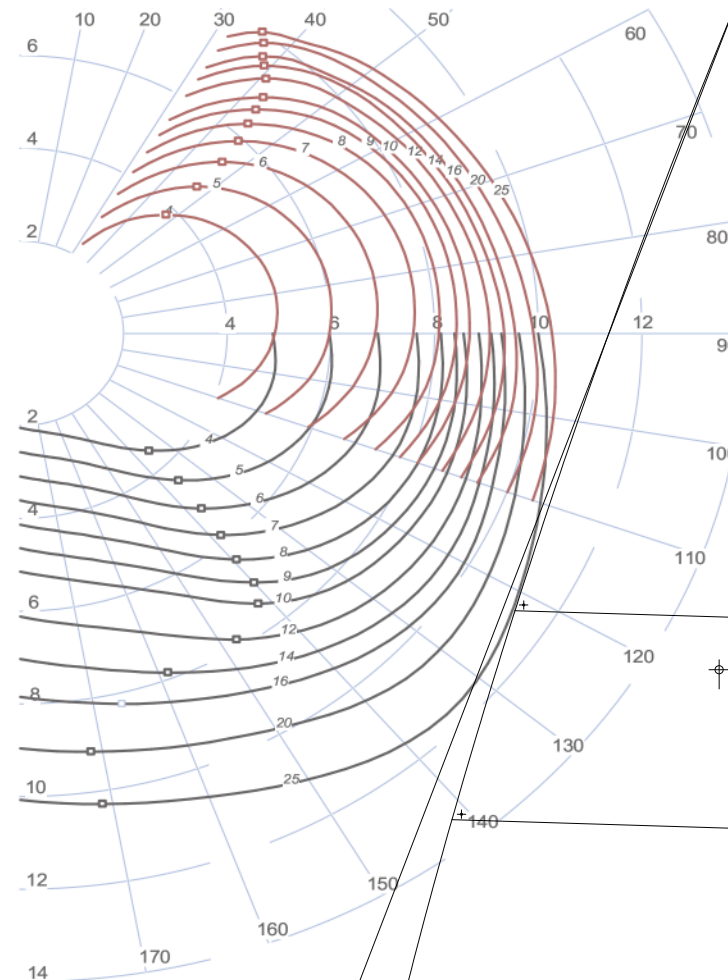

"The Outbound is, in brief, a fabulous boat. She's fast, well balanced and the details are right. She's a terrific boat for going to sea.."

Bill Biewenga, 4 time Round The World race veteran after an Outbound 44 transatlantic delivery.

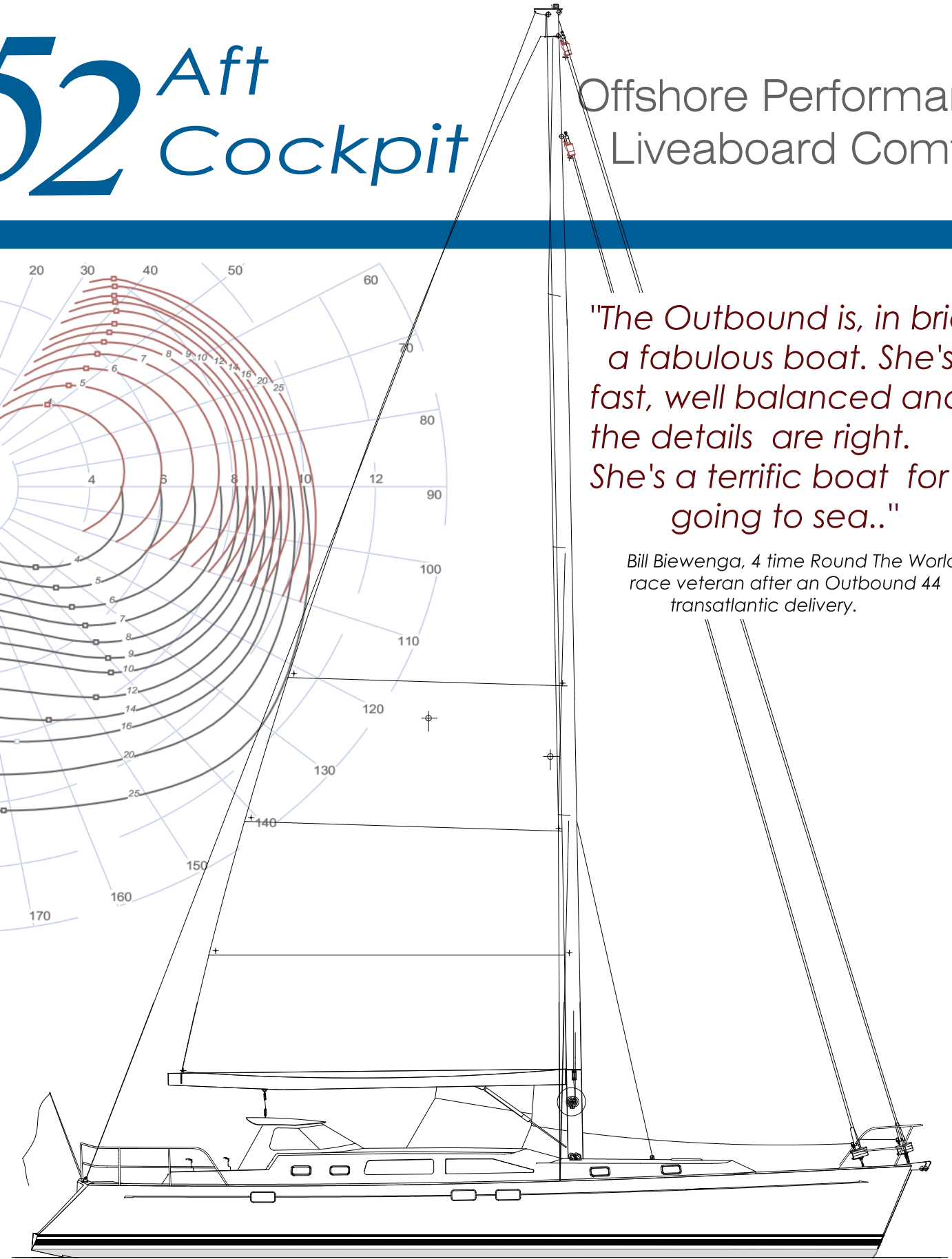

Outbound 52 Center Cockpit



Outbound 46

LOA:	52'00"
DWL:	47'10"
Beam:	15'4"
Draft:	6'6"/7'0"
Disp.:	42,000
Ballast:	14,000
Sail Area:	1312
Water:	225gal.
Fuel:	250gal.
SA/Disp:	18.35
Disp/Length:	160

Offshore Performance - Liveaboard Comfort ... for the Ultimate in Cruising Safety

Experienced sailors know the added safety that comes with good sailing performance. The ability to sail off a lee shore, to fetch a safe harbor that is dead upwind, or to shorten a passage to within the available weather window are key safety factors that should not be overlooked when selecting your next yacht.

With deliveries, living aboard, and racing in our background, our first goal was to develop a well behaved and easily driven yacht ... not just for speed but for the safety that comes with performance and control. Our second goal was to create as much comfort as possible ... not just for living aboard, but to reduce fatigue on offshore passages and ensure a well rested crew.

The solid fiberglass construction and elegant hand crafted interior of an Outbound offers the displacement required to give the yacht an easy and forgiving motion but its lines and parameters define performance ... long waterline, moderate beam, high righting moment, proper weight distribution, and efficient foils. Raising the cabin sole and house a few inches allows for 225 gallons of water and 250 gallons of fuel directly over the keel, adding stability, upwind performance, and stowage ... and creates the light and airy cabin required for a long and pleasant cruising experience.

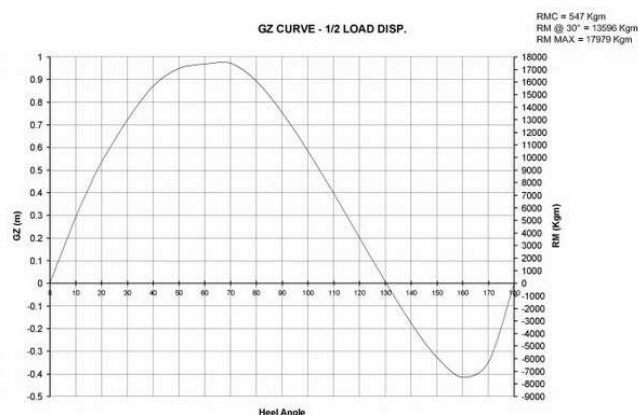
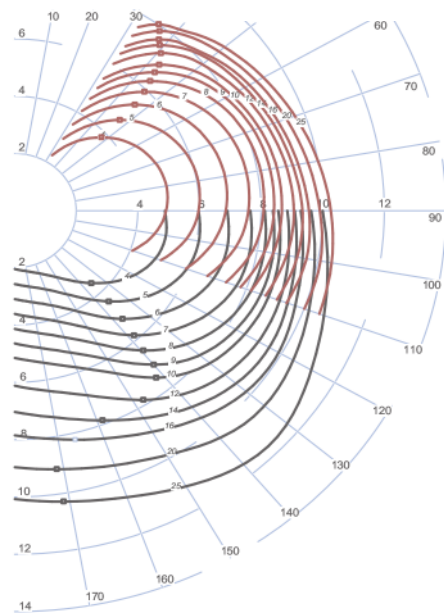
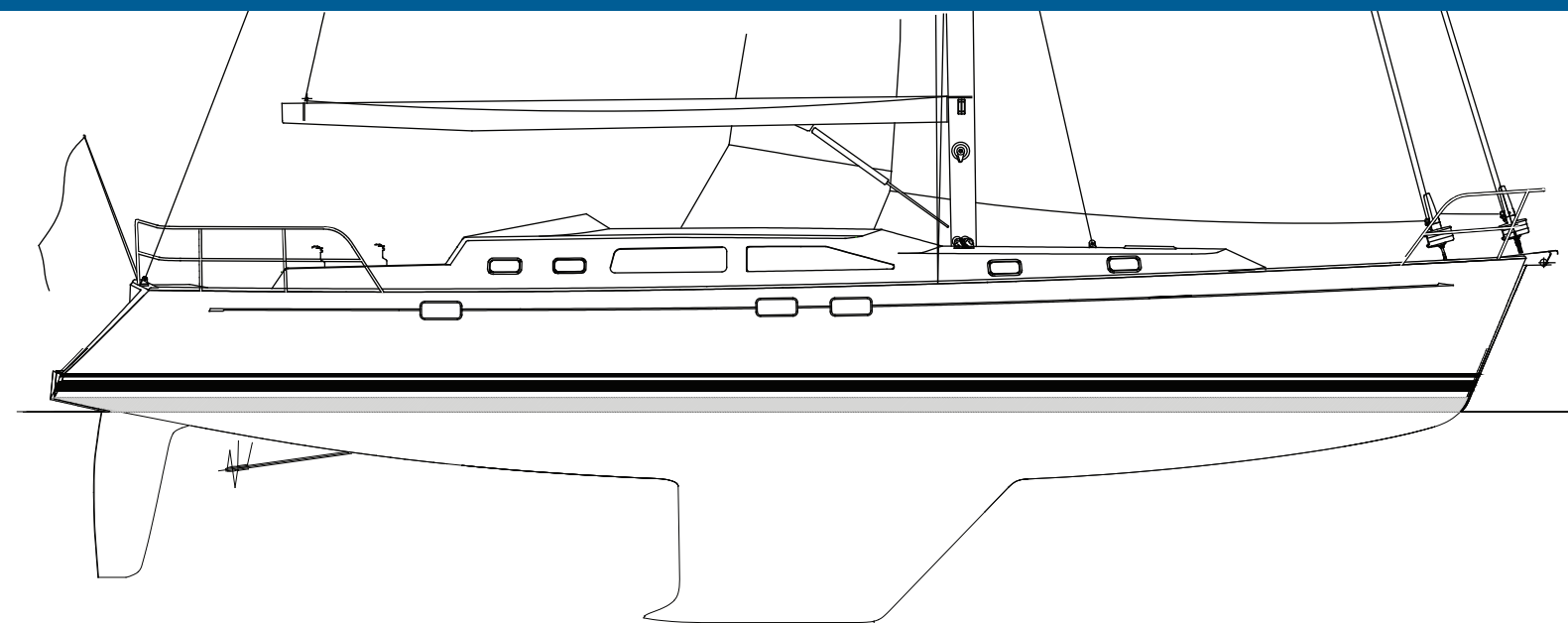

Photos Outbound 46

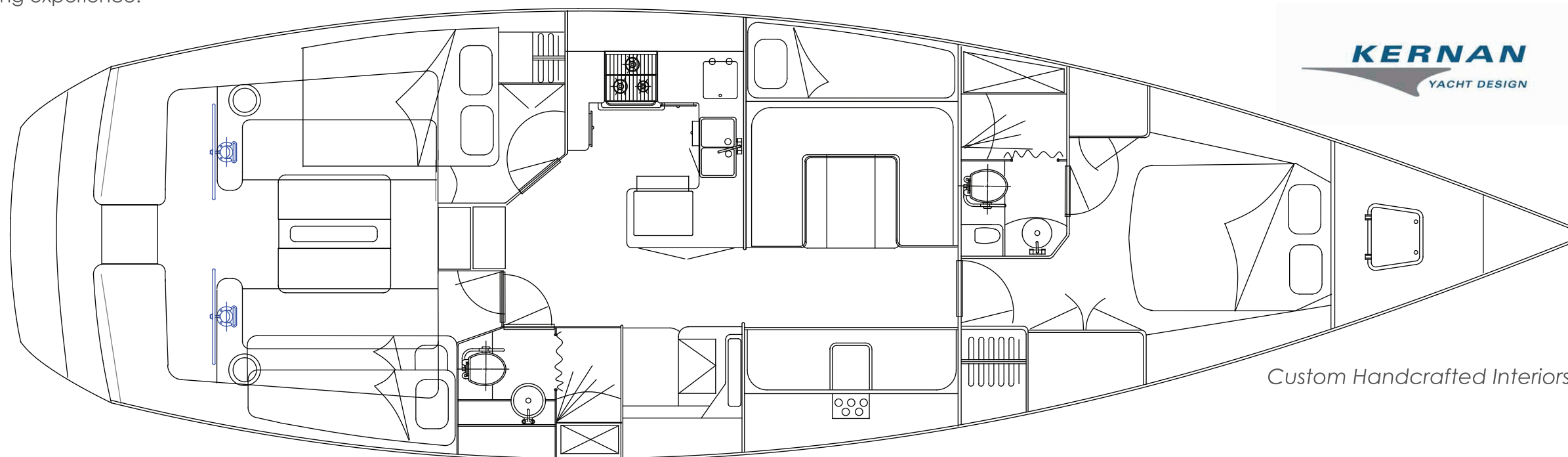

KERNAN
YACHT DESIGN

Custom Handcrafted Interiors